

00021 HYDRAULIC POWER UNIT

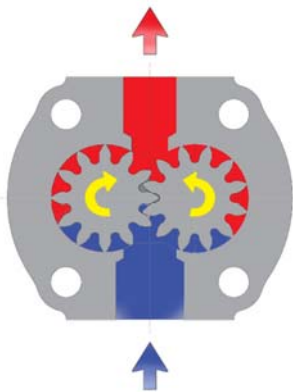

COZZINI
APPLICATION SPECIFIC EQUIPMENT



The gear pump provides positive displacement for reliable hydraulic power

00021 HYDRAULIC POWER UNIT

- Compact power for lifting or lowering dumpers.
- Powered with 7.5 hp (5.6 kW) washdown duty stainless motor and reliable 9.5 gpm (36 lpm) gear pump.
- Standard 10-gallon (38 liter) stainless steel reservoir.
- Reservoir lid design features a lip to prevent water from contaminating hydraulic oil.
- Durable design for dependable operation.
- Portable or stationary styles available.
- Optional electrical box may be added to operate hydraulic unit.
- USDA accepted and CE approved. Built in conformity with AMI sanitary equipment design principles.

00021 HYDRAULIC POWER UNIT

The Cozzini 00021 hydraulic unit is designed to meet your hydraulic power requirements. All of our custom-designed hydraulic units are built rugged for longer-lasting dependability with durable, continuous welds on the reservoir. Dependability and easy maintenance are designed into the hydraulic unit from the very beginning.

The hydraulic unit is typically used to provide hydraulic pressure to raise a dumper to the desired height. The unit operates at a preset pressure of 1200 PSI. With Cozzini's optional controls, the unit can automatically start when raising or lowering a dumper and for safety, will shut off after a period of inactivity. While the hydraulic unit comes standard with a 10-gallon reservoir, optional models can hold as little as 3 gallons (11 liters) or as much as 25 gallons (95 liters).

Our hydraulic units are not alike. Cozzini can also custom design the hydraulic unit to meet your needs: portable or stationary, electric or manual controls, all with a stainless steel, glass bead finish. We provide numerous options and fabrication styles depending on the requirements.

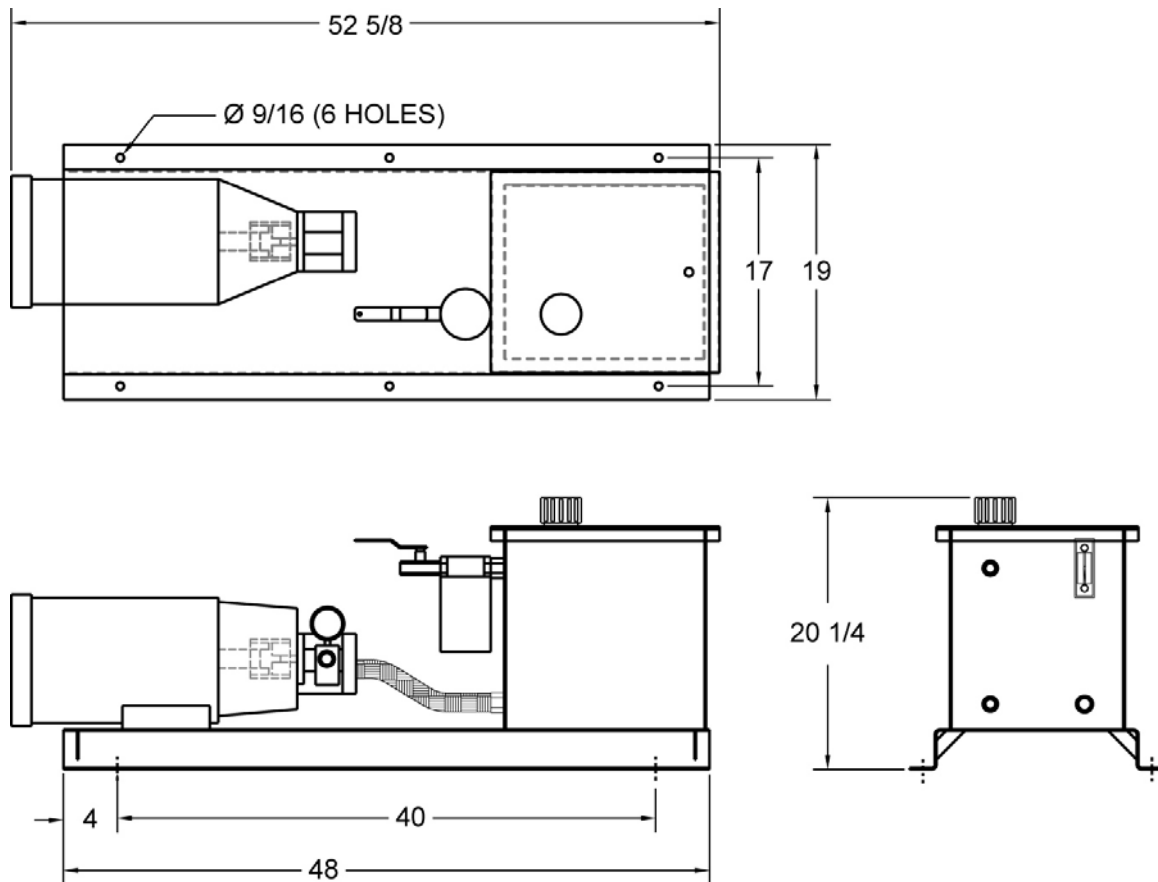

4/08 E

WORLD HEADQUARTERS Cozzini, Inc.
4300 West Bryn Mawr Avenue Chicago, IL 60646-5943 U.S.A

COZZINIGROUP
COMPLETE FOOD EQUIPMENT SOLUTIONS

WORLD REPRESENTATION • 773 478-9700 • www.cozzini.com • sales@cozzini.com