

HOLLOW GRINDER



PRIMEEdge®
COZZINI CUTTING EDGES
AND SHARPENING SOLUTIONS



Unique cup wheel
sharpening stone design
assures consistent grind
bevel widths.

HOLLOW GRINDER

Models HG4CU and HG6CU

- Ideal for high-volume knife users.
- Available with Ø4" (102 mm) or Ø6" (152 mm) cup stones.
- Thins blades for edging up to 16" (406 mm) long.
- Recirculating liquid coolant system provides burn-free and dust-free operation.
- Integrated, pneumatically-controlled, stone dressing system maintains roundness of the cup stones for perfect, consistent, sharp edges.
- Built-in Go/No-Go gauge determines at a glance if the blade is thinned enough for edging and honing.
- CE approved.

HOLLOW GRINDER

For efficient, high-volume knife sharpening operations, Cozzini HGCU Grinders are used to thin blades prior to edging and honing. 4" (102 mm) or 6" (152 mm) cup stones provide the unique advantage of maintaining the same stone bevel and diameter as the stones wear, thereby assuring a consistent grind bevel width. When combined with our Honer/Edger (HE7) as part of a centralized knife sharpening system, productivity increases and ergonomic problems decrease.

The ergonomic design of the Hollow Grinder provides operator comfort and safety. An adjustable, pivoting lamp can be oriented in different positions for excellent visibility while grinding blades. The sturdy stainless steel body with fiberglass cover provides long life and easy maintenance access.

For a consistent and precise blade thinning operation, trust the proven HGCU series of Grinders from Cozzini.

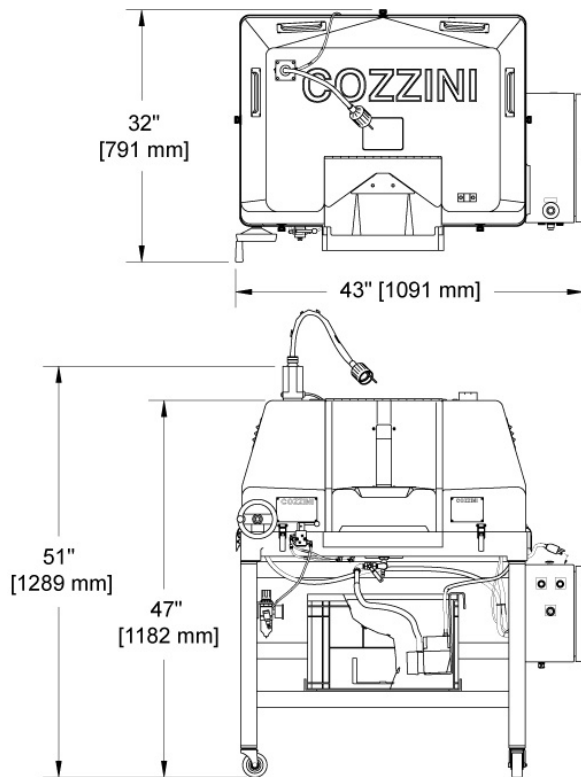

HOLLOW GRINDERS				
Model	Voltage	Phase	HP	kW
HG4CU	220 V	1	.50 (x2)	.4 (x2)
	230/460 or 380 V	3	.50 (x2)	.4 (x2)
HG6CU	220 V	1	.75 (x2)	.6 (x2)
	230/460 or 380 V	3	.75 (x2)	.6 (x2)

10/05 E

WORLD HEADQUARTERS Cozzini, Inc.
4300 West Bryn Mawr Avenue Chicago, IL 60646-5943 U.S.A.

COZZINIGROUP
COMPLETE FOOD EQUIPMENT SOLUTIONS

WORLDWIDE REPRESENTATION | 773.478.9700 | COZZINI.COM | SALES@COZZINI.COM